

NEW!

LAMBDA 

UP

ZERO-UP 200W/400W/800W Programmable DC Power Supplies

**Built-in RS232 & RS485 Interface
with GPIB optional.**

- Constant Voltage/Constant Current
- Built-in RS232 & RS485 Interface
- An embedded Microprocessor controller
- Digital Encoder Knob
- Software Calibration
- Last Setting Memory
- Parallel Operation (Master/Slave) Active Current Sharing
- External Voltage or Resistance Programming
- Voltage up to 120V, Current up to 132A
- Active Power Factor Correction: 99%
- 85~265Vac Universal Input Voltage
- 19" Rack Mounted ATE and OEM
- Worldwide Safety Agency Approvals
- CE Mark for LVD and EMC Regulation



Control Flexibility for Worldwide Applications



Product Line Up

Model	Output Voltage (VDC)	Output Current (A)	Output Power (W)
ZUP6-33	0 ~ 6 VDC	0 ~ 33	198
ZUP6-66		0 ~ 66	396
ZUP6-132		0 ~ 132	792
ZUP10-20	0 ~ 10VDC	0 ~ 20	200
ZUP10-40		0 ~ 40	400
ZUP10-80		0 ~ 80	800
ZUP20-10	0 ~ 20VDC	0 ~ 10	200
ZUP20-20		0 ~ 20	400
ZUP20-40		0 ~ 40	800
ZUP36-6	0 ~ 36VDC	0 ~ 6	216
ZUP36-12		0 ~ 12	432
ZUP36-24		0 ~ 24	864
ZUP60-3.5	0 ~ 60VDC	0 ~ 3.5	210
ZUP60-7		0 ~ 7	420
ZUP60-14		0 ~ 14	840
ZUP80-2.5	0 ~ 80VDC	0 ~ 2.5	200
ZUP80-5		0 ~ 5	400
ZUP120-1.8	0 ~ 120VDC	0 ~ 1.8	216
ZUP120-3.6		0 ~ 3.6	432

Power Supply Identification / Accessories

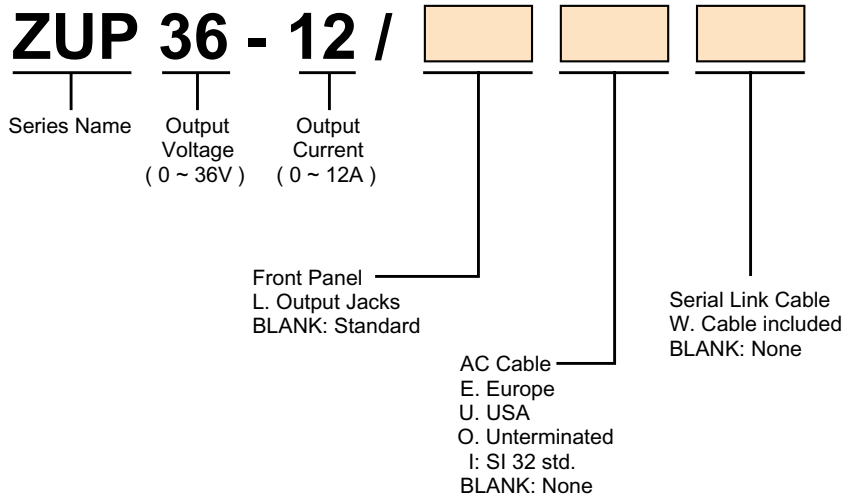

NEW
NEW
NEW
NEW

Front Panel



- Digital Voltmeter
- Digital Amperemeter
- Constant Voltage Mode Indicator
- Constant Current Mode Indicator
- Voltage/Current, OVP/UV, Address Adjust
- Alarm (OVP, OTP, FOLD)
- Output ON/OFF Control
- Local/Remote Select
- Foldback Protection Control
- AC Power Switch
- Voltage/Current Mode Control
- Overvoltage/Undervoltage Setting
- Address Setting

Rear Panel

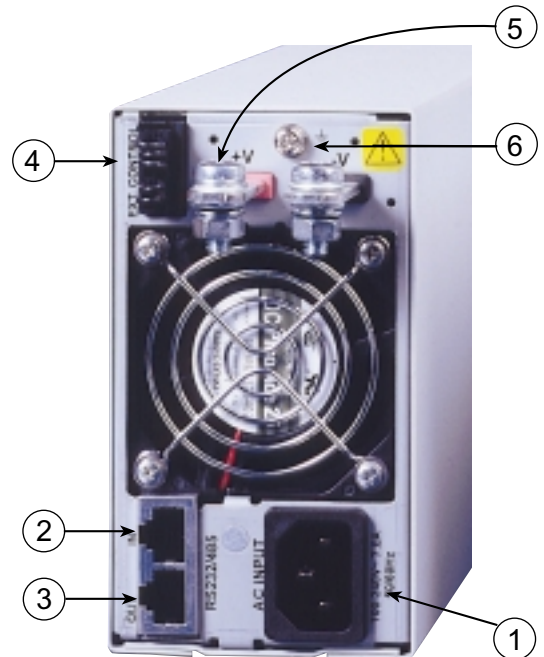

- IEC320 AC Input Connectors
- Remote IN Programming via RS232/485
- Remote OUT Via RS485 Communications Chaining Power Supplies to Serial Communication Bus.
- External Analog Programming Control Connector
- Output Bus Bars (6V to 60V) model shown. 80V to 120V models PHOENIX: PSC Plug Connectors
- Ground Thread

ZUP Configurations

BENCH TOP POWER SUPPLY

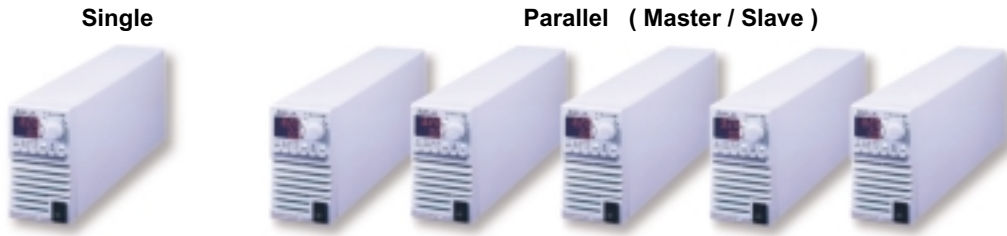

PARALLEL OPERATION

Master - Slave method: Active current sharing up to 5 units.

REMOTE PROGRAMMING VIA RS232

Up to 31 ZUP units can be controlled via RS232 interface.

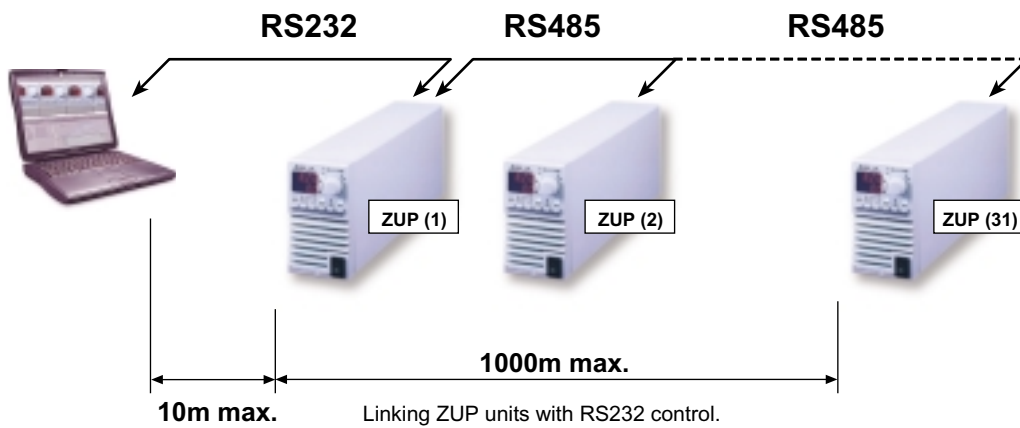

REMOTE PROGRAMMING VIA RS485

Up to 31 ZUP units can be controlled via RS485 interface.

For operation environments that require high noise immunity or long distance communication, it is recommended to use the built-in RS485 interface.

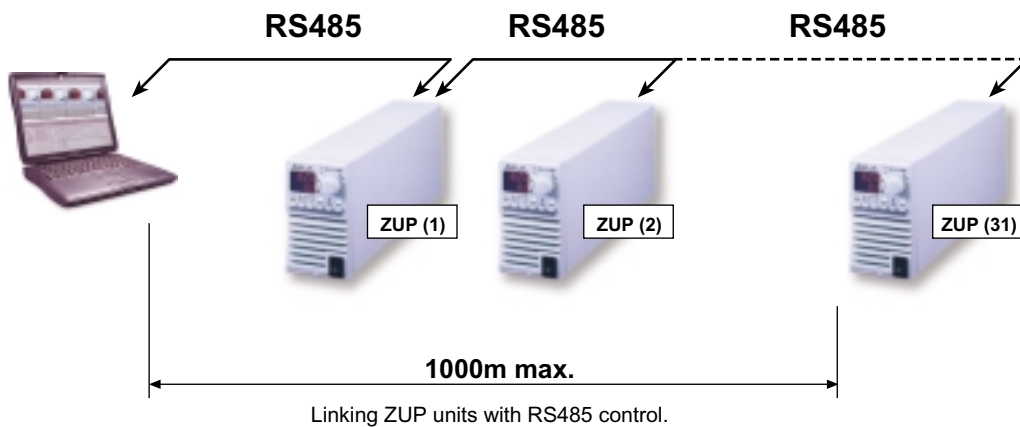

Remote Programming Via GPIB.

GPIB ↔ RS485 CONTROLLER

The GP485 is a high performance serial to GPIB Interface
 It enables a ZUP series with RS485 port to be a Talker, Listener, or controller on the GPIB

- * Controls up to 31 ZUP units through a single GPIB address.
- * Conforms to all versions of the IEEE488 standard, including IEEE488.2.
- * 19 racking possibility.
- * Application software - LabView, LabWindows.

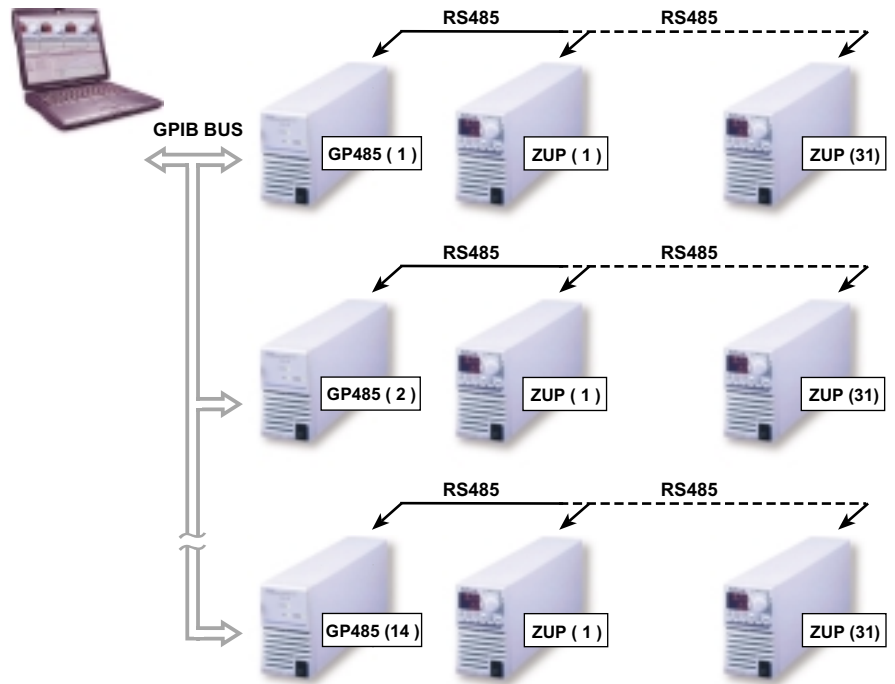

Rack Mounted ATE and OEM up to 2.4KW

Six units can be assembled into 19-inch rack / 3U high to meet your configuration requirements

Power Modules Table

Module Type	200W	400W	800W
0 ~ 6V	33A	66A	132A
0 ~ 10V	20A	40A	80A
0 ~ 20V	10A	20A	40A
0 ~ 36V	6A	12A	24A
0 ~ 60V	3.5A	7A	14A
0 ~ 80V	2.5A	5A	
0 ~ 120V	1.8A	3.6A	
19"rack width	1 / 6 width	1 / 6 width	2 / 6 width



Zup Series Specifications

MODEL		ZUP6-33	ZUP6-66	ZUP6-132	ZUP10-20	ZUP10-40	ZUP10-80	ZUP20-10	
OUTPUT VOLTAGE (*1)		V	0-6			0-10			
OUTPUT CURRENT (*2)		A	0-33	0-66	0-132	0-20	0-40	0-80	0-10
RATED OUTPUT POWER		W	198	396	792	200	400	800	200
CONSTANT VOLTAGE	LOAD REGULATION	-	0.005%+2mV From No load to Full load, constant input voltage.						
	LINE REGULATION	-	0.005%+1mV From 85-132VAC or 170-265VAC, constant load.						
	RMS RIPPLE (5Hz-1MHz Bandwidth)	mV	5	5	8	5	5	8	5
	RIPPLE (pk to pk) (20MHz Bandwidth)	mV	50	50	100	50	50	90	50
	RECOVERY TIME (*3)	mS	1			0.5			
	TEMPERATURE COEFFICIENT	-	30ppm/...C from rated voltage following 30-minute warm-up.						
	TEMPERATURE DRIFT	-	0.01%+2mV Change in output over 8-hour interval under constant line, load and ambient temp following 30-minute warm-up.						
	UP PROGRAMMING RESPONSE TIME (*4)	mS	50	50	60	50	50	60	50
	DOWN PROGRAMMING RESPONSE TIME	FULL LOAD	mS	50	50	50	50	50	50
	NO LOAD	mS	250			350			
CONSTANT CURRENT	LOAD REGULATION (*5)	-	0.01%+5mA	0.01%+5mA	0.07%+10mA	0.01%+5mA	0.01%+5mA	0.07%+10mA	0.01%+5mA
	LINE REGULATION (*6)	-	0.01%+2mA	0.01%+2mA	0.01%+5mA	0.01%+2mA	0.01%+2mA	0.01%+5mA	0.01%+2mA
	RMS RIPPLE (5Hz-1MHz Bandwidth)	mA	50	100	200	25	50	100	15
	TEMPERATURE COEFFICIENT	-	100ppm/...C from rated current following 30-minute warm-up.						
	TEMPERATURE DRIFT (*8)	-	0.02%+5mA	0.02%+5mA	0.05%+10mA	0.02%+5mA	0.02%+5mA	0.05%+10mA	0.02%+5mA
PROGRAMMING (*9)	RESOLUTION	-	Better than 0.028% of rated output voltage						
	VOLTAGE ACCURACY	-	0.02%+5mV			0.02%+8mV			
	RESOLUTION	-	Better than 0.03% of rated output current						
	CURRENT ACCURACY	-	0.4%+40mA						
OVERVOLTAGE PROTECTION (*10)	V	0-7.5			0-13				
HOLD-UP TIME	-	20mS At 100V/200VAC, rated output voltage and output current.							
DISPLAY	VOLTAGE	-	3 digits (6v; 20v; 36v; 60v; 80v); 3.5 digits (10v; 120v) accuracy: 0.2% +/- 2 digits.						
	CURRENT	-	3.5 digits (132A); All others 3 digits, accuracy: 0.5% +/- 3 digits.						
	STATUS	-	CV/CC, Alarm, Fold, Local/Remote, On/Off.						
OUTPUT PROTECTIONS	-	Over Voltage, Over Temperature, Foldback.							
INPUT	INPUT VOLTAGE (*11)	-	85-265Vac Continuous, 47-63Hz						
	INPUT CURRENT (*12)	A	3.0/1.5	5.6/2.7	11.2/5.4	2.9/1.4	5.6/2.7	11.2/5.4	2.9/1.4
	INRUSH CURRENT (100/200V)	A	15/30 (*7)	15	30	15/30 (*7)	15	30	15/30 (*7)
	EFFICIENCY (*12)	%	69/72	74/77	74/77	73/77	79/82	77/81	74/78
	INPUT CURRENT HARMONICS	-	Complies with EN61000-3-2, Class A						
	POWER FACTOR (TYP)	-	0.99 at 100/200Vac, 100% load.						
ENVIRONMENT	OPERATING TEMPERATURE	-	0 to 50 ...C ; 100% Load.						
	OPERATING HUMIDITY	-	30-90% RH (No dewdrop).						
	STORAGE TEMPERATURE	-	-20 to 70 ...C						
	STORAGE HUMIDITY	-	10 - 95% RH (No dewdrop).						
MECHANICAL	VIBRATION	-	10-55Hz, Amplitude (sweep 1 min) 2G, X, Y, Z, When mounted with mounting screws.						
	SHOCK	-	Less than 20G						
	WEIGHT	Kg	2.9	3.2	5.8	2.9	3.2	5.8	2.9
	SIZE (WxHxD)	mm	200W and 400W units: 70 x 124 x 350. 800W units: 140 x 124 x 350 (Refer to outline drawing)						
EXTERNAL CONTROL FUNCTIONS	OUTPUT ON/OFF	-	By TTL Signal or Dry Contact (Refer to instruction manual).						
	OUTPUT GOOD	-	Open collector (Refer to instruction manual).						
	OUTPUT VOLTAGE PROGRAMMING	-	By Voltage (0-4V) or by Resistance (0-4K) (Refer to instruction manual).						
	OUTPUT CURRENT PROGRAMMING	-	By Voltage (0-4V) or by Resistance (0-4K) (Refer to instruction manual).						
	REMOTE SENSING	-	Maximum 0.5V drop on each load wire for model up to 60V and 2V for the 80V, 120V models						
	COMMUNICATION INTERFACE	-	RS232 and RS485 Built-in, IEEE488 Optional.						
APPROVALS	SAFETY STANDARDS	-	UL3111-1, EN61010-1						
	EMC STANDARDS	-	EN61326-1, IEC 61326-1, FCC part 15 (class A).						
CONDUCTED EMI	-	EN55022-B, FCC-B, VCCI-2							
RADIATED EMI	-	EN55022-A, FCC-A, VCCI-1							
SERIES OPERATION	-	Up to 2 units (Refer to instruction manual).							
PARALLEL OPERATION	-	Master - Slave method; up to 5 units (Refer to instruction manual).							
COOLING	-	Forced air by blower fan (Blower fan is mounted within unit).							
WITHSTAND VOLTAGE	-	Input - Chassis...2.0kVAC 1 min, Input - Output...3.0kVAC 1 min, Output - GND...500VAC 1 min.							
ISOLATION RESISTANCE	-	More than 100MOhm at 25 ...C and 70% R.H.							

NOTES:

- *1. Minimum voltage is guaranteed to maximum 0.2% of the rated output voltage.
- *2. Minimum current is guaranteed to maximum 0.4% of the rated output current.
- *3. Time for recovery to within +/-50mV against current change of 50% to 100%.
- *4. From zero volts to full scale, resistive load and current setting at maximum.
- *5. From no load to full load, constant input voltage.
- *6. From 85~132Vac or 170~265Vac constant load.
- *7. At cold start Ta=25 ...C.

- *8. Change in output over 8 hour interval constant line, load and ambient temperature following 30-minutes warm-up.
- *9. Given for control of the output via the serial communication or via front panel controls.
- *10. Inverter shut down method, manual reset (OVP will shut down output)
- *11. For cases where conformance to various safety specs. (UL, IEC, etc.) are required, to be described as 100-240VAC (50/60Hz) on name plate.
- *12. At 100V/200V and Maximum Output Power.

GP485 SPECIFICATIONS

The GP485 has all the software and logic required to implement the physical and electrical Specifications of the IEEE488 and RS485 standards

Input Voltage /freq	Vac	85 ~ 265Vac continuous 47 ~ 63 Hz
Input consumption	W	5W
IEEE 488 Capability		SH1,AH1,T6,TE0,L4,LE0,SR1,RL0,PP1,DC1,DT0,C0,E1,E2
Indication LED's		Power /Ready ,Talk ,Listen ,SRQ
Baud rate	bps	Optional 300 , 600 ,1200 , 2400 , 4800 , 9600 Default :9600
Address		1 up to 30 can be set using an address switch
Operating temp	°C	0~ 50
Storage temp	°C	-20 ~ 70
Conducted emission		EN5022B,FCC-B
Radiated emission		EN5022A,FCC-A
Safety standards		UL3111-1 , EN61010-1
EMC standards		EN61326-1, IEC 61326-1, FCC part 15 (class A).
Withstand voltage		Input - Chassis 2.0kVAC 1min, Input - Output 3.0kVac 1 min, Output - Chassis 500VAC 1 min.
Vibration	G	10-55Hz, Amplitude (sweep 1 min) 2G, X, Y, Z, When mounted with mounting screws.
Size (WxHxD)	mm	70x124x350 (GP 485 has all the mechanical specifications & mounting hole as ZUP200W/400W units)
Weight	Kg	1.95

Front Panel

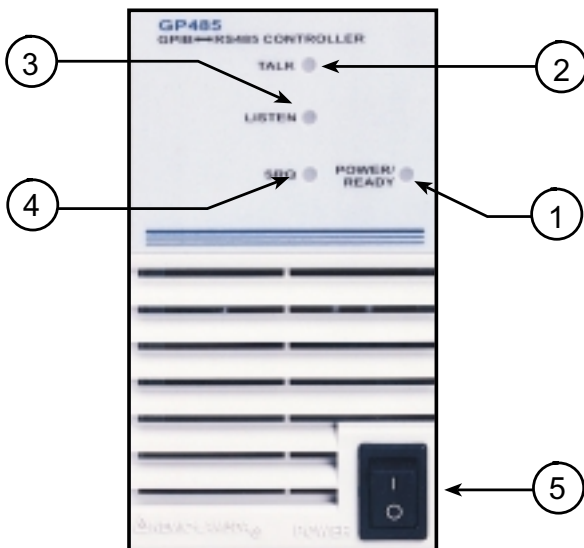

1. Power/Ready: Indicates that the power is ON and the self-test has passed successfully. The unit is ready to operate once the LED illuminates.
2. Talk: Indicates that the GP485 is addressed as a GPIB Talker.
3. Listen: Indicates that the GP485 is addressed as a GPIB Listener.
4. SRQ: Indicates that the GP485 signal line SRQ is asserted.
5. AC ON/OFF: Turns AC power On and Off.

Rear Panel

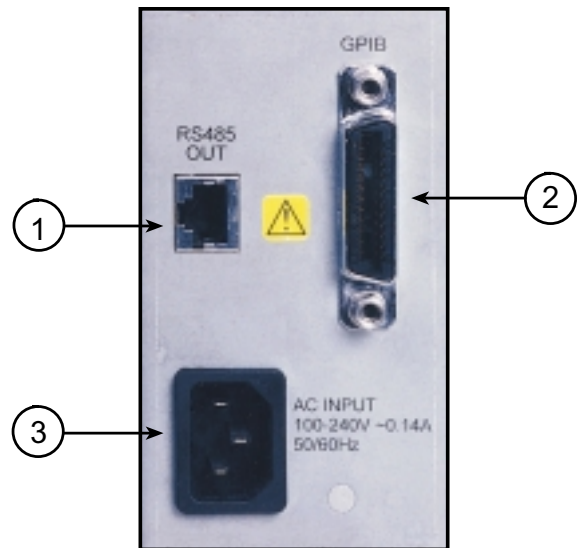

1. RS485 OUT: EIA-568A shielded type connector, used for RS485 communication with ZUP power supplies.
2. GPIB: Shielded 24-pin Champ female connector, with metric screwlock. Used for GPIB communication with the GPIB controller.
3. AC Input: IEC type appliance inlet.
4. XXXXXXXXXXXXX

Outline Drawings ZUP 200W/400W Units

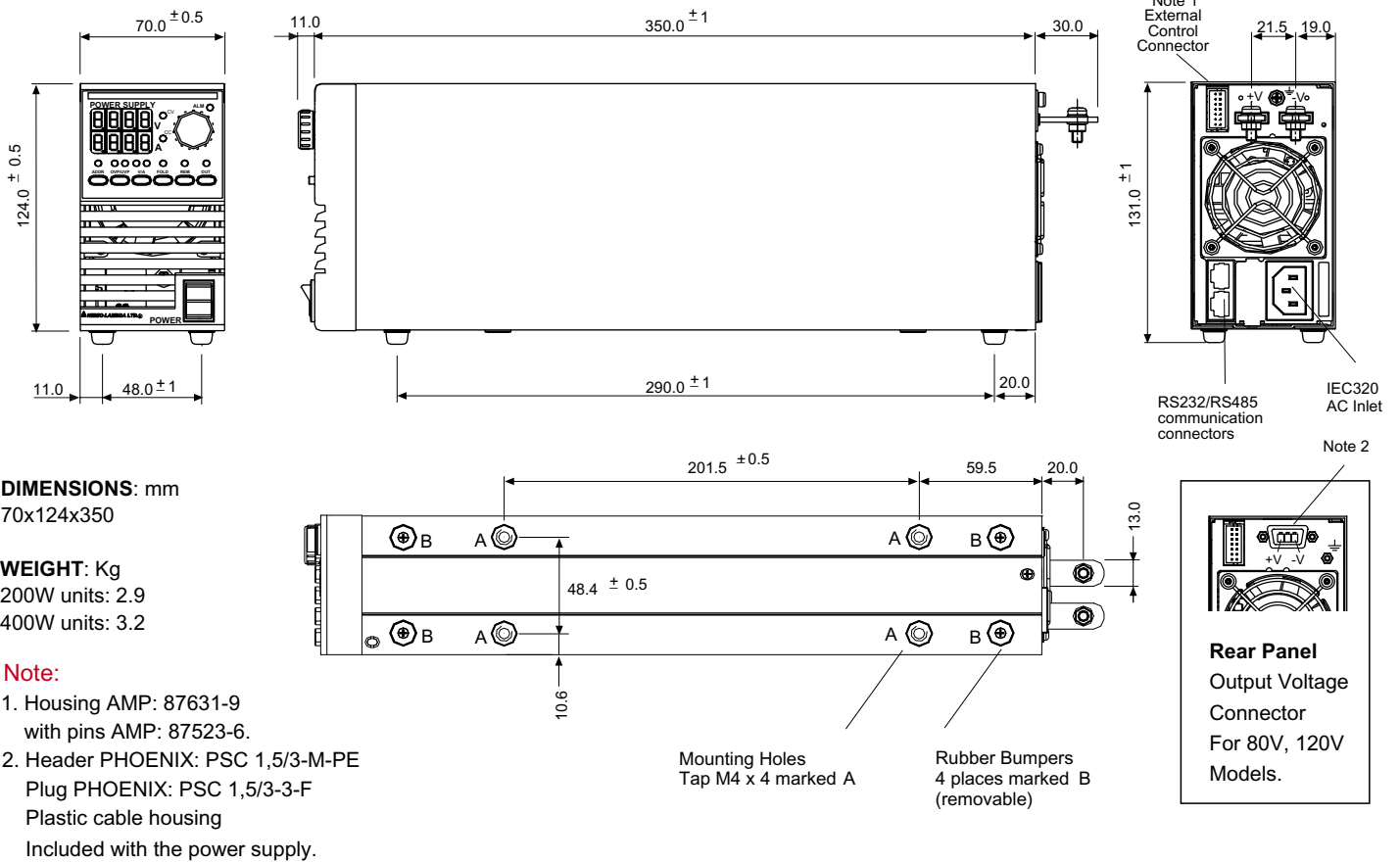

Outline Drawings ZUP 800W Unit

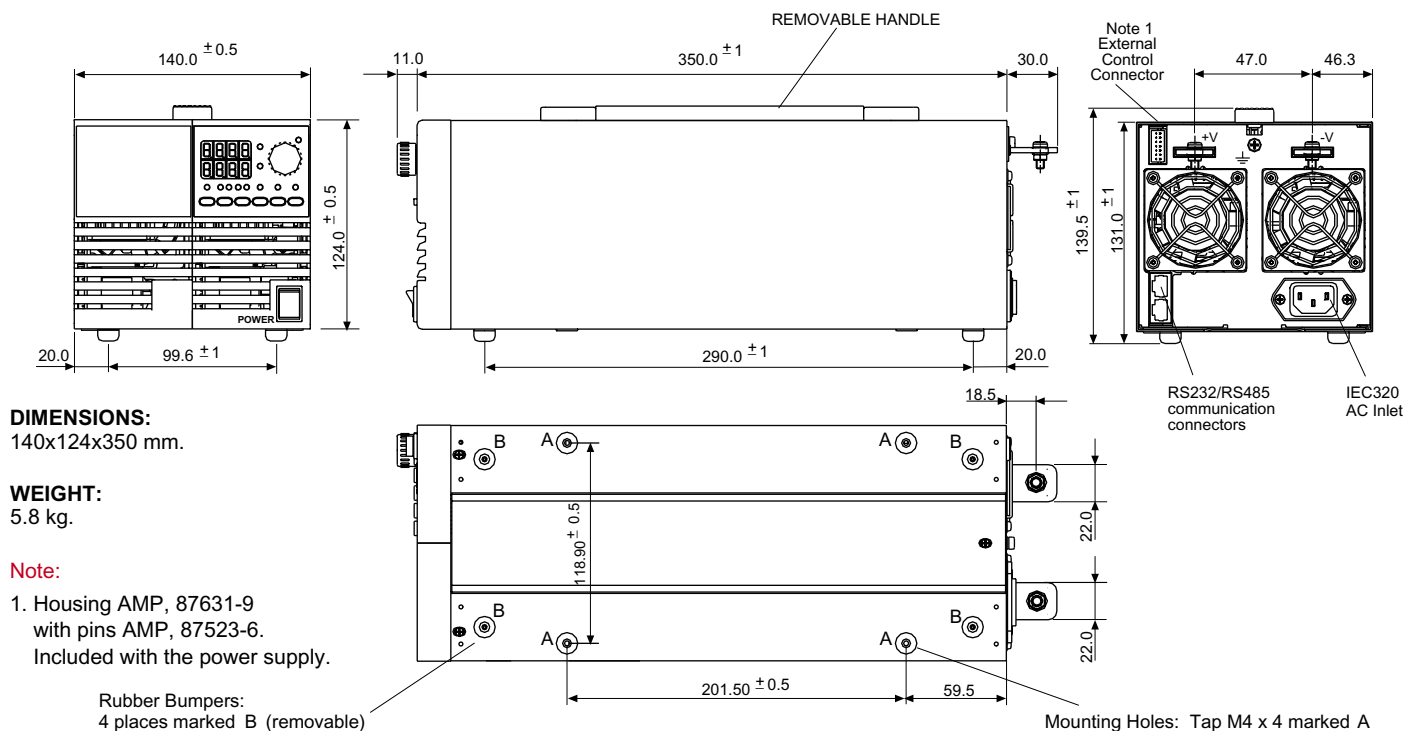

Accessories

1. AC Cord Sets

Three optional cords are possible according to order:

Region	AC Cord	Power Supply Connector	Wall Plug	P/N
North America	15A / 125Vac L=2m	IEC320-C13	NEMA 5-15P	ZUP/U
Europe	10A / 250Vac L=2m	IEC320-C13	INT'L 7/ VII	ZUP/E
SI- 32 Std	10A / 250Vac L=2m	IEC320-C13	SI-32	ZUP/I



North America



Europe



SI-32 Standard

2. Communication Cable

RS232/RS485 cable is used to connect the power supply to the PC controller

Mode	PC connector	Communication cable	Power Supply Connector	P/N
RS232	DB-9	Shield Ground , L=1m	EIA / TIA-568A (RJ-45)	ZUP/NC401
RS232	DB-25	Shield Ground , L=1m	EIA / TIA-568A (RJ-45)	ZUP/NC403
RS485	DB-9	Shield Ground , L=1m	EIA / TIA-568A (RJ-45)	ZUP/NC402
RS485	DB-25	Shield Ground , L=1m	EIA / TIA-568A (RJ-45)	ZUP/NC404



DB-25 (female connector)

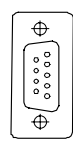
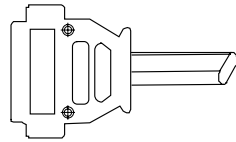

DB-9 (female connector)

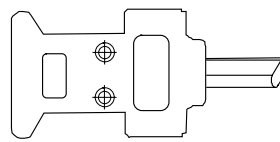

EIA/TIA (RJ-45)

3. ZUP serial link cable

Used to chain Power Supply to Power Supply from a serial communication bus

Mode	Communication cable	Power Supply Connector Remote IN /OUT	P/N
RS485	Shield Ground , L=50cm	EIA /TIA -568 A (RJ-45)	ZUP/ W

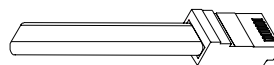
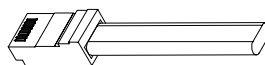

Options (200W, 400W, 800W Models)

1. FRONT PANEL OUTPUT JACKS
P/N: ZUP / L

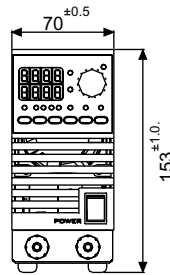

Outline Drawing: Physical Dimensions in mm.
ZUP 200W/400W Units: 70x153x405.9
ZUP 800W Units: 140x153x405.9

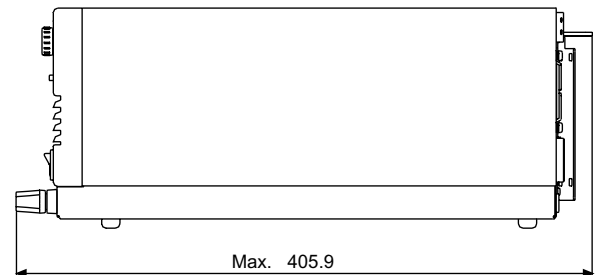

Up to 20A output current via front panel jacks.

2. ZUP ASSEMBLIES
Dual Output Packing 200W/400W models
P/N: NL200

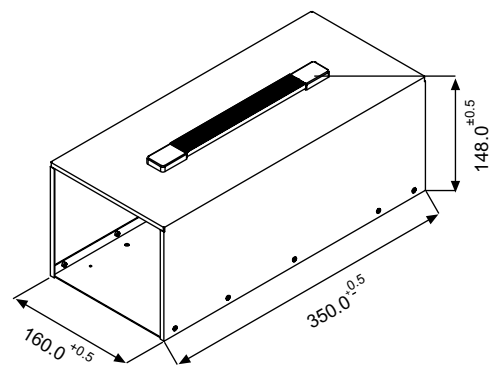

3. 19" RACK MOUNTED ATE AND OEM UP TO 2.4 KW
Up to six power units can be assembled into a 19 , 3U rack, kit P/N NL100.
In cases where the entire rack is not occupied with power units, NL101 blank panels can be installed.
P/N: NL100

